

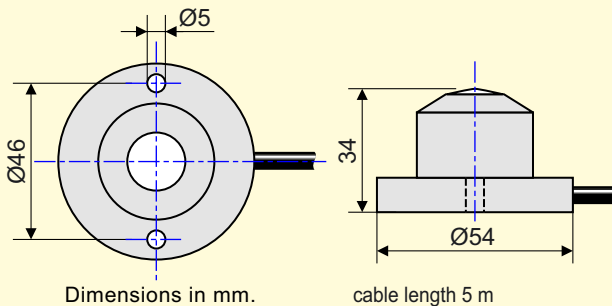

Dimensions



SPECIFICATIONS

| | |
|------------------------|--|
| Spectral range | 400 - 1100 nm |
| Sensitivity (nominal) | 100 $\mu\text{V}/\text{W}/\text{m}^2$ |
| Response time | less than 1 s |
| Max. irradiance | 2000 W/m^2 |
| Temperature dependence | +0.15 %/ $^{\circ}\text{C}$ (typical) |
| Operating temperature | -30 $^{\circ}\text{C}$ to +70 $^{\circ}\text{C}$ |
| Directional error | ± 5 % at 80 degrees |

SP LITE is easy to use. It can be directly connected to voltmeter or data logger. Direct readout in Watts per square meter (W/m^2) can be derived from the measured voltage divided by the calibration coefficient.

The SP LITE Silicon Pyranometer compares favourably to ISO 9060-specified First Class Thermopile Pyranometers under clear & unobstructed natural daylight conditions, and fully complies with CE Directives.

Recommended use:

SP LITE is designed for routine measurement of solar radiation. It is especially designed for:

- Photo Voltaic / solar energy module monitoring
- Agricultural evapotranspiration estimation
- Air pollution dispersion calculations using the Delta-T method
- Educational purposes

SP LITE can be used under all weather conditions. The sensor measures the solar energy received from the entire hemisphere.

SP LITE is ideal for measuring available energy for use in solar energy applications, plant growth, thermal convection and evapotranspiration.

SP LITE uses a photodiode detector, which creates a voltage output that is proportional to the incoming radiation. Also due to the unique design of the diffuser, its sensitivity is proportional to the cosine of the angle of incidence of the incoming radiation, allowing for accurate and consistent measurements.

Directional response

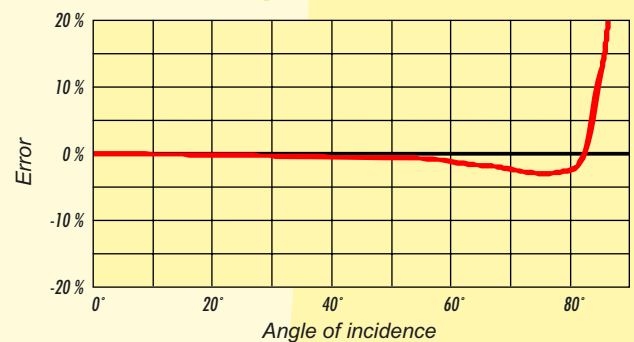

Spectral response

