



# WindSonic Ultrasonic Wind Sensor



## Description

The WindSonic is a low-cost alternative to mechanical wind sensors. Without the need for on-site calibration or maintenance and with a corrosion-free exterior, it is a true 'fit and forget' unit.

## Construction

The WindSonic is of a robust, high strength construction. The external design is corrosion free and, with no moving parts, is designed to withstand installation and use without the damage that can occur with traditional mechanical units.

The WindSonic is designed to be mounted using a standard pole-type fitting and comes complete with all screw fittings and a mating marine grade connector.

Using ultrasonic technology the WindSonic provides accurate results in weather conditions where traditional mechanical wind sensors may fail.

## Operation

The WindSonic is based on proven, highly successful, ultrasonic technology. It is designed to be easily configurable to deliver the information you require.

Used in connection with Campbell Scientific dataloggers you can select the output rate and units of measurement to suit your application. To ensure accuracy and reliability, the WindSonic automatically transmits an anemometer status code with each output to indicate its operating status.

The WindSonic is supplied with SDI-12 output as standard.

*See overleaf for full specifications.*

## Key Features

Measures wind speed and direction

Consistent performance throughout life

Wind speed measurement range 0.01 to 60m/s

No dead band for wind direction

No calibration required

Robust, corrosion free UV-resistant material

Direct connection to Campbell Scientific dataloggers using SDI-12 output

## Typical Applications

Environmental Studies/Wind Resource Surveys

Agriculture

Pollution Control

Portable/Roadside Weather Stations

HVAC

Marine Environments

## Specifications

### Outputs

Output: 1 output per second in SDI-12 mode; 1, 2 and 4 outputs per second in other communication modes.

Parameters: Wind speed and Direction or UV

Measurement Units: m/s in SDI-12 mode; knots, mph, kph, ft/min also available in other communication modes.

### Wind Speed

Range: 0 to 60ms<sup>-1</sup> (130mph) for maximum accuracy; gust survival 100ms<sup>-1</sup> (220mph)

Accuracy: ±2%

Resolution: 0.01ms<sup>-1</sup>

### Wind Direction

Range 0 to 360° – no dead band

Accuracy: ±3°

Resolution: 1°

### Anemometer Status

Message supplied as part of standard output

### Power Requirement

Anemometer: 9-30V DC at 40mA (typical)

### Communication Modes:

Standard SDI-12 (as supplied).

The sensor can be reconfigured in RS232, RS422 or RS485 modes. (Please specify when ordering, as these modes require different cable configurations.)

### Environmental

Moisture Protection: IP65

Operating Temperature: -35° to +70°C

Operating Humidity: <5% to 100%

### EMC

BS EN50081-1:1992 (emissions class B)

BS EN 50082-1:1997 (immunity)

### MTBF

10 years

### Materials

External construction:

LURAN S KR 261/1C ASA/PC

### Dimensions

Size: 142 x 160mm

Weight: 0.5kg

### Standards

Manufactured within ISO9001 quality environment

### Optional Factory Calibration

Traceable to national standards

### Mounting

Pipe Mounting 44.45mm (1.75 in) outside diameter

## Mounting

The instrument mounts on standard 44.45mm (1.75ins) outside diameter pipe. Campbell Scientific can supply crossarms suitable for tripod or tower use, which includes a suitable mounting post. The instrument can be rotated as required – an arrow on the underside indicates North to assist correct alignment.

See mounting diagram below.

The sensor is supplied with an unwired connector as standard. It can optionally be fitted with a suitable length of cable and connector if specified when ordering.

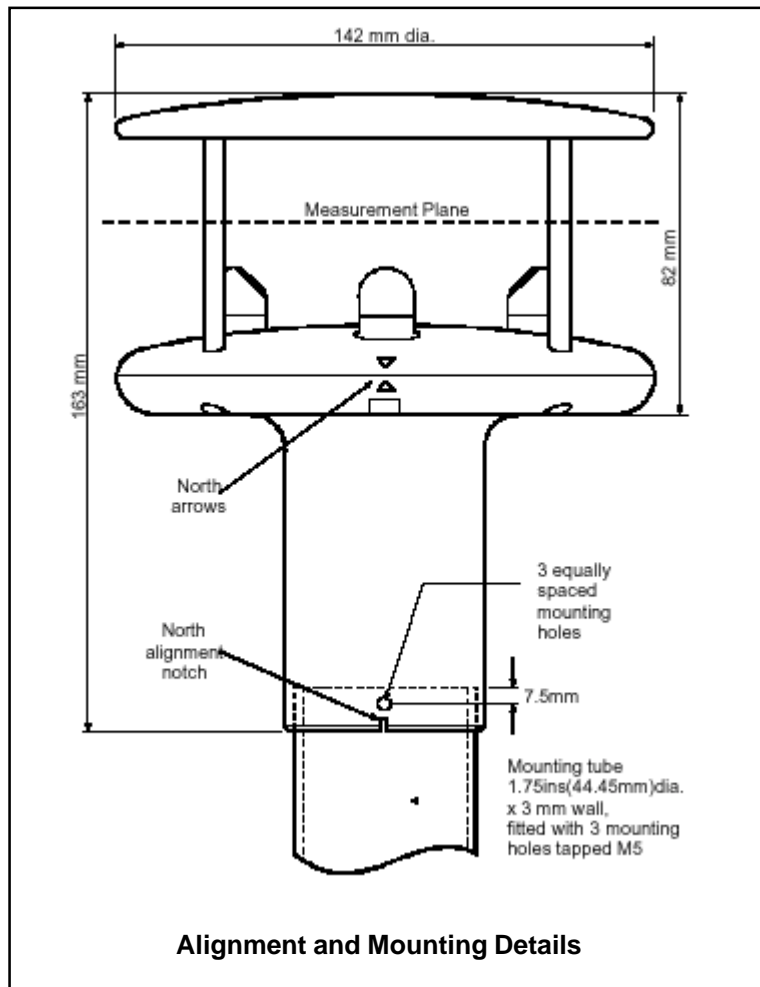

Please call for further information on the WindSonic and other wind sensors and weather stations

June 2004

Campbell Scientific products are available from: